

B15

Lug Type Butterfly Valve

Product Description

DENZ B15 Lug Type Butterfly Valves are constructed with the centered disc rotating 90 degrees inside the valve body. Fluid flow can be stopped, regulated, or started using the actuation type. With a lug type connection, the valve can be installed between the pipe flanges and tightened with bolts and nuts.



Application Areas

- HVAC Systems
- Pumping Stations
- Water Treatment Plants
- Reservoir and Tanks
- Irrigation
- Industrial Applications
- Desalination Plants

Operation

Manual	Bareshaft
	Handlever
	Manual Gearbox
Electrical actuator	Quarter turn electrical actuator 220V AC on/off
	Quarter turn electrical actuator 24V DC on/off
Pneumatic actuator	Pneumatic actuator single acting
	Pneumatic actuator double acting
	Pneumatic actuator w/ gearbox and emergency handbrake
Accessories	Position indicator
	Limit switch

Production References

Size Range	DN40-300
Pressure Range	PN10-16
Temperature	EPDM: +80°C NBR: 60°C VITON: 120°C
Design	EN 593
Face to Face	EN 558 Series 20
Connection	EN 1092-2 Lug Type
Coating	Electrostatic Powder Epoxy
Testing	EN12266-1
Marking	EN 19



HVAC



Sea Water



Potable Water



Waste Water



B15 Lug Type Butterfly Valve Material Selection					
Disc/Seat	EPDM	NBR	PTFE	VITON	PTFE
Nickel Plated DI	B15-01	B15-02	B15-03	B15-04	-
SS304	B15-05	B15-06	B15-07	B15-08	B15-09
SS316	B15-10	B15-11	B15-12	B15-13	B15-14
Al-Bronze	B15-15	B15-16	B15-17	B15-18	B15-19
PTFE	-	-	-	-	B15-20

Product Features



- Direct mounting of gearboxes, pneumatic actuators, or electric actuators is possible with ISO5211 top angles.
- Low pressure lost
- Face-to-face interaction in accordance with EN 558 series 20
- GG25 Cast Iron Body as Standard (Optionally GGG40)
- As per EN 12266-1 rate A, tightness at 16 bars or 10 bars
- There is an integral seal (with a liner vulcanized on a hard ring) that avoids any contact between the valve body and the fluid.
- Sealing design ensures perfect adhesion to the valve body and perfect tightness to the flanges, without requiring any additional parts.
- The torque of the valve is not affected by clamping between flanges.
- The disc edges are lapped to improve tightness, reduce torque, and reduce wear on the liner.
- Supporting bushings for the shaft.
- Valve neck with top work in accordance with EN ISO 5211 allows for easy connections with all types of actuators.
- All components have been properly treated against corrosion.
- Single stem & light weight design
- Easy installation
- Bidirectional sealing
- Comes with hand lever as standard.
- During operation, the anti-blow-out stem ensures safety
- Installation to the pipelines does not require additional gaskets
- Maintenance-free, easy to replace spare parts
- Safety is ensured during operation due to the anti-blowout stem
- Gaskets are not required for installation on the pipeline
- As a result of its long neck design, it can be used as an insulation material
- This valve is not suitable for use at the end of a line
- 100% of the valves are subjected to Hydrostatic tests according to EN 12266-1. Pressure for seat: PN x 1.1 , for shell: PN x 1.5



* PTFE Disc and Sealed Lug Butterfly Valves are available at DENZ stocks.





Material List <<<<

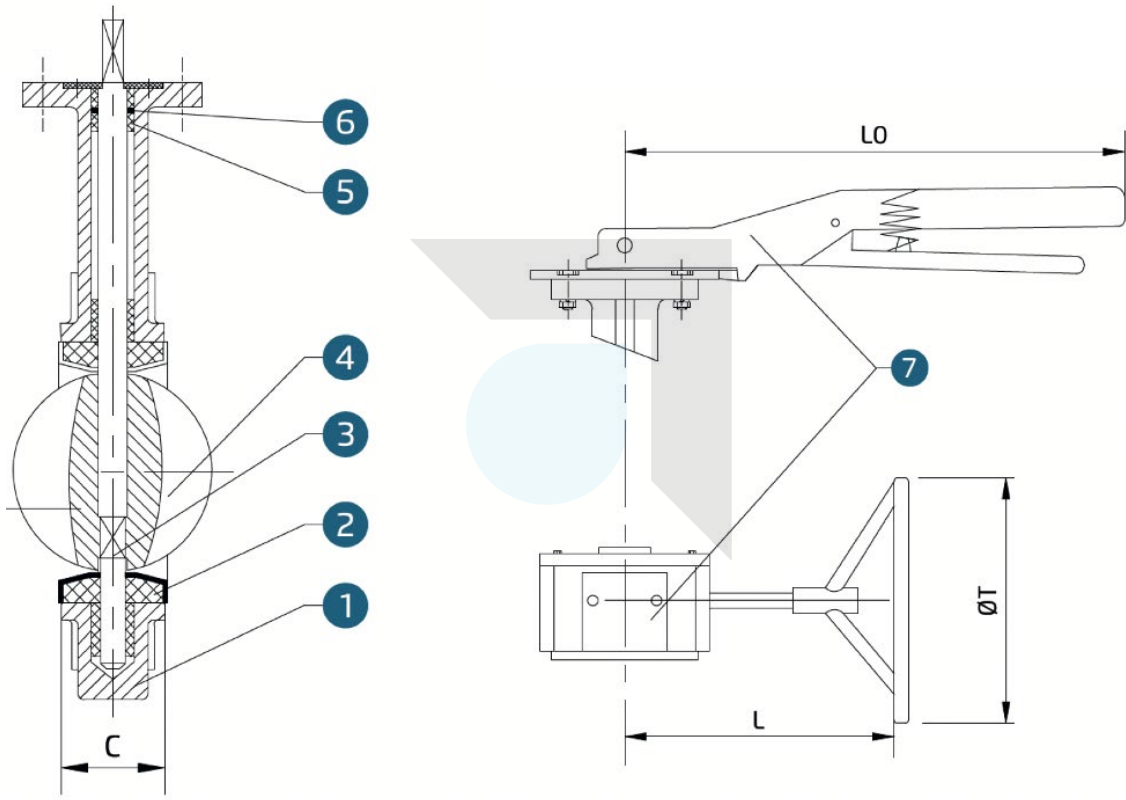

#	Part	Material
1	Body	GG25 / GGG40
2	Seat	EPDM / NBR / VITON / PTFE
3	Stem	Stainless Steel AISI 420
4	Disc	Nickel Plated DI / AISI 304 / AISI 316 / AluBronz
5	Bushing	PTFE
6	O-Ring	NBR
7	Lever	Aluminium



Dimensions

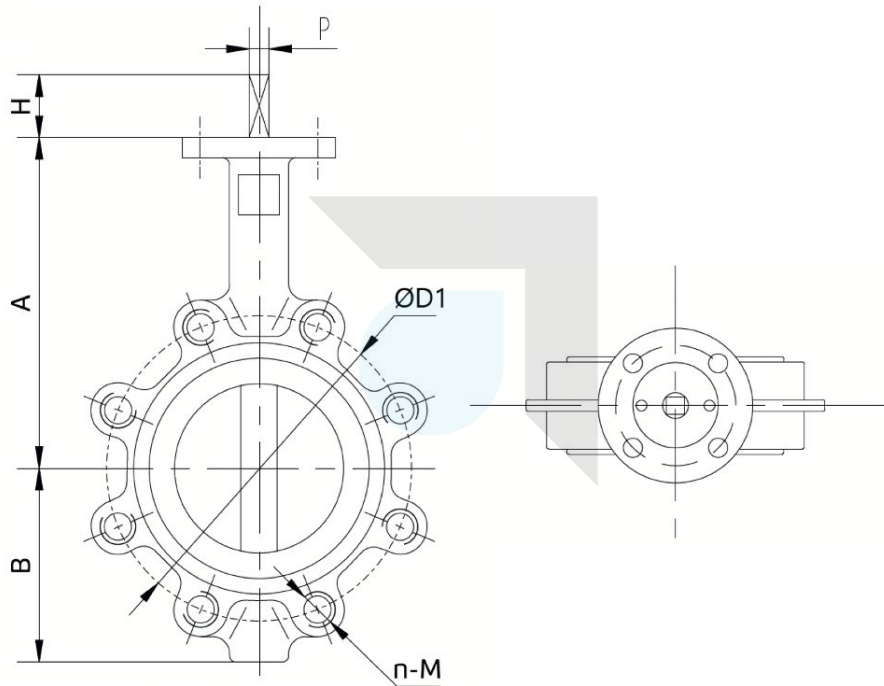

DN	A	B	H	P	C	ISO 5211 Top Flange	LO	T	L	D1	PN16
40	125	68	30	9	33	F05	215	137	150	110	4-M16
50	129	73	30	9	42	F05	215	137	150	125	4-M16
65	137	82	30	9	44,7	F05	215	137	150	145	4-M16
80	144	95	30	9	45,2	F05	215	137	150	160	8-M16
100	163	109	30	11	52,1	F07	260	137	150	180	8-M16
125	179	125	30	14	54,4	F07	260	137	150	210	8-M16
150	198	144	30	14	55,8	F07	260	137	150	240	8-M20
200	237	173	30	17	60,6	F10	355	269	207	295	12-M20
250	281	211	30	22	65,6	F10	355	269	207	355	12-M24
300	318	244	30	22	76,9	F10	355	269	207	410	12-M24

Units: mm / indicative dimensions & weights

General

The DENZ Butterfly Valves, available in wafer or lug versions, range in size from DN 40 to DN 400 (lug DN 300), and can be used in a variety of industrial applications.

The following general requirements are in accordance with UNI EN 593:

Working Conditions

Fluids

The valves are designed and tested for use with all fluids in Group 1, either liquid or gaseous, according to Directive 2014/68/EU.

It will be the responsibility of the operator or the engineering firm in charge of the project to select valve materials that are chemically and physically compatible with the intercepted fluid. In the best interest of customers, the DENZ technical staff is available to assist them in selecting the best product for a specific application. Ultimately, it will be up to the operator or engineering firm to make the final decision.

Working pressure

DENZ Butterfly Valves are designed for continuous use at maximum pressures of 16 bar between DN 40 and DN 300, as well as 10 bar between DN 350 and DN 400. It is essential that the maximum working pressure equals the PN valve pressure.

Working temperature

DENZ B Series Butterfly Valves have been designed and tested for continuous operation while maintaining the PN value unchanged across a wide range of temperatures. Below are the maximum and minimum working temperatures for seal materials:

EPDM: +80°C NBR: 60°C VITON: 120°C

Lubrication

A factory lubricant is applied to the butterfly valves during their installation for the standard working condition life. Make sure the lubricant to be used during maintenance and reassembling is appropriate for contact with the seal material, the fluid intercepted, and the operating conditions.

External protection

Butterfly valves of the DENZ B Series can be installed both indoors and outdoors. 160-200 microns of epoxy paint protect the cast-iron body from corrosion. The shaft and the disc are in stainless steel or protected by the corrosion.

Marking and classification

The marking on the body and metal label will be according to EN19.

Operating Information

There are three types of butterfly valves: those supplied bare shaft, those fitted with a lever for manual operation, and those equipped with electric or pneumatic actuators.

Handle-operated

In the case of a valve equipped with a handle, the handle must be assembled in such a way that, when viewed from above, it must be rotated clockwise to close the valve and counterclockwise to open it. An open valve should have its handle parallel to the pipeline, while a closed valve should have its handle in its usual position with respect to the pipeline. The handle needs to be stopped (and even locked) in ten different positions angularly equidistant from one another all along the valve stroke.

Automated valve

A wide variety of applications can benefit from the use of automated valves, including those requiring full control, efficiency and long-term durability. There are three types of connections between a valve and an actuator:

- A) Direct Mounting
- B) Mounting Plate Connection
- C) Bracket & Joint Connection

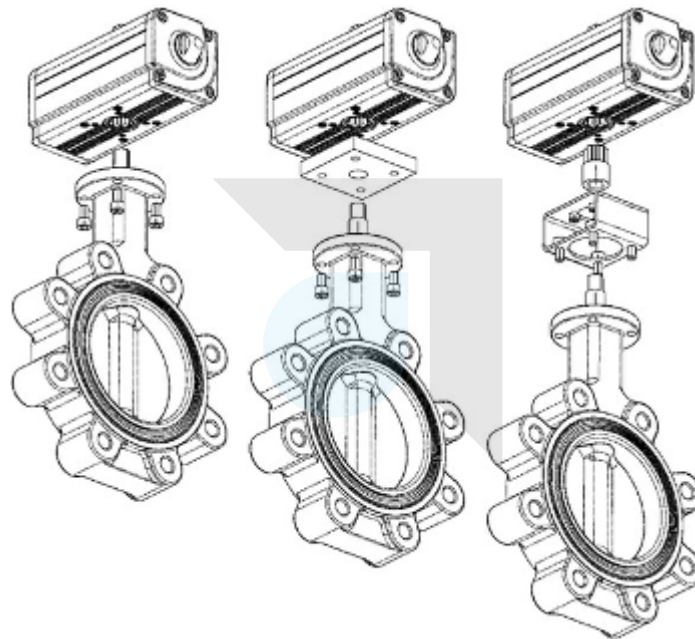



A) Direct Mounting

The direct mounting of valve actuators is the most effective method of preventing plays between the valve stem and actuator drive shaft. The valve and actuator must have the same standard flange connections and the valve stem dimensions must match perfectly with the actuator drive in order to be installed directly. Verify that the actuator and valve flange ISO connections are the same size before installation; verify that the valve stem size and shape are suitable for direct mounting, if necessary, utilize a drive reduction. Bolt the ISO flanges together and insert the valve stem into the actuator drive shaft connection.

B) Mounting Plate Connection

A mounting plate adapter with suitable flange dimensions allows an easy connection allowing enough space for the valve/actuator drive adapter to fit if direct mounting is not possible.

C) Bracket & Joint Connection

The bracket and joint is the appropriate solution where, for technical reasons, a distance is required between the actuator and the valve, or the valve flange and/or stem are not standard, and where a valve/actuator connection cannot be achieved. This bracket is a steel bridge allowing you to connect a valve with its own flange connection on one side and the appropriate actuator connection on the opposite side, leaving a space in between for a steel joint connection.

7 Designed for stem key drives and flat heads, this joint provides a drive connection between the actuator and the valve stem. In order to secure the actuator very tightly to the valve without any play, choose the appropriate flange bracket and the necessary joint connections. As a result of its drainage channels system on the flange connection pattern, the DENZ actuator has been specifically developed for direct mounting of valves.. This system allows to drop away any possible flow coming from the valve stem that with valve/actuator direct mounting could damage the actuator.

Cycle Time

The cycle time of the valve is determined by the operating device that is attached to it. It is important that you read the instructions regarding the actuator you have installed. The interface between valve and actuator should comply with ISO 5211 connection standard.

Flow rate of the valve

Based on the size of the valve, the construction type of the valve (centric drive) ensures a few degrees of seal before complete closing. During assembly, actuators are adjusted to close the valve at an angle of 87 ° - 88 °, enabling the valve to seal at nominal pressures without requiring excessive torque. It is recommended that the run be increased to 90 degrees in order to ensure that the product has a long life

A stroke adjustment up to 90 degrees allows for the recovery of the wear of the gaskets, thus extending the life of the product.





Safety Information

- When you receive a product, make sure it is in perfect conditions. Do not install a product which comes in a damaged box especially if it shows signs of damage.
- While the valve is being installed, make sure that the pipeline and the working environment are perfectly clean. The presence of dirt and particles can seriously affect the tightness of the valve. If you use a sealing product, either tape or paste, make sure that it will not end up in the valve body or in the sealing areas.
- If an aggressive or dangerous fluid flows through the valve, make sure the material the valve is made of is compatible with the fluid. If you have any doubt, please contact DENZ staff who will carefully evaluate the chemical compatibility of the fluid with the valve.
- A valve is a safe product provided that it is properly installed between flanges on a pipeline. If you want to test a valve at the bench, especially a pneumatically operated one, make sure there are protections enough to prevent objects and parts of your body to get caught between the butterfly and the valve body. Please remember that a valve closes in less than a second and with enough energy to damage itself and a careless operator.
- Before installing a valve, make sure that the operating temperature and pressure are compatible with the parameters stated by the manufacturer.
- If a valve is used as an END OF LINE valve, please remember that it has not been tested for that specific function. For an END OF LINE application, please note that the valve PN corresponds to 60% of the PN stated for an installation in a pipeline.
- Never try to disassemble a valve or any of its parts when there is fluid in the pipeline regardless of the pressure
- Never remove the valve shafts when there is pressure in the pipeline as the butterfly could be swallowed by the fluid under pressure in the pipeline.

Installation

- A risk assessment based on EU standards for this kind of product could not fully evaluate the risks associated with traffic, wind, earthquakes, etc. as every evaluation was based on the type of application and installation.
- It is the owner's responsibility to carry out this evaluation, where necessary, along with an assessment of the pipeline's risks. In addition to being very easy to install, DENZ Butterfly Valves perform at their best when you follow some basic installation procedures.
- Never attempt to force a valve through flanges that do not allow the valve to be inserted due to the risk of serious damage to the sealing area on the flanges (fig. 1).
- In the course of inserting the valve between the flanges and blocking them, the disc must be kept in a half-open position without exceeding the valve edges (Fig. 2).
- Support the butterfly by means of two tie-rods which, passing through the holes in the flanges and the slots on the valve body, will allow for a generic centering of the flanges in the initial stage. Upon slight closure of the four tie-rods (opposite to each other), center the valve body carefully with respect to the pipeline flanges (a correction of +/- 1mm on a DN 50 and proportionally of +/- 5mm on a DN 300 is acceptable).





As the bolts are closed on the flanges, the torque generated does not have a significant effect on the valve. Consider the material of the bolts as well as the torque stated in the relevant standard.

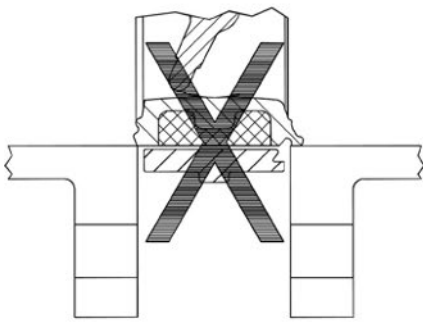

fig. 1

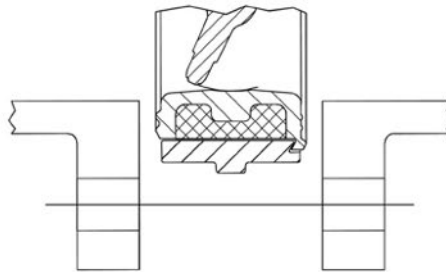

fig. 2

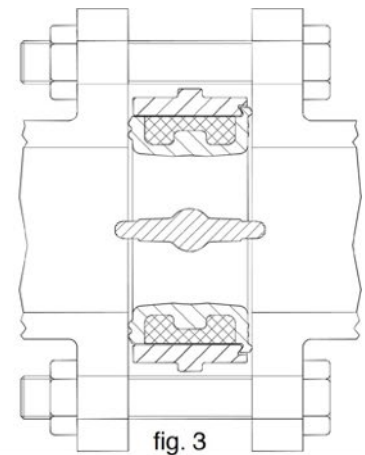

fig. 3

Materials and The Durability of Materials

In order to ensure the full reliability of the valve, it is recommended to conduct a check of its efficiency level at least once a year, replacing all worn-out parts promptly where leaks or strains are experienced, both within the pipeline and outside the valve. In summary, the consumable parts have a lifetime of the following. In order to maintain valves, spare parts kits are available, please ask support from your local sales representative of DENZ.



Maintenance

Maintaining the product must be done by trained and qualified professionals with the right tools. We recommend that the valves are tightened and functionally tested before replacing them.

- Remove the spring pins with a punch or the shaft retention flanges, in the case of measures of more than DN 300.
- Remove the shaft. For measures of more than DN 300, the bottom of the shaft is not prevalent and can be removed using an M16 bolt.
- Remove the disc. The operation is facilitated by rotating the disk 15° from the closed position.
- Remove the main seal noting that in the flange are, it has two different diameters; obviously, it must be extracted by pushing on the smaller diameter. It is recommended to use a hydraulic press with thrust plate diameter of 15 mm more than the valve DN.
- Check that the o-rings, also came out with the main seal; if not, remove them from the valve body.
- Remove the upper bushing
- The bushings are not normally replaced during maintenance. Should it be necessary to remove them, contact our technical department for instructions.
- Place the o-rings and in their seats after thorough greasing.
- Insert the main seal into the valve body, aligning the shaft holes as well as possible with the corresponding holes in the body.
- Insert the disc, aligning the shaft holes as well as possible with the corresponding holes in the seal. Keep the disc rotated at 15°.
- Insert the upper bushing
- Reposition the shafts in their relative seats, until the groove of the rod reaches the same level as the pin hole (up to DN 300 only). During insertion, there may be a slight resistance due to the slight misalignment of the components; use moderate force to insert the shafts; where necessary re-check the alignment of the components. Pay attention to the groove on the head of the shaft, which must be exactly in line with the butterfly valve position. Insert the pins or assemble the shaft holder flanges.
- Always run a valve seal test before recommissioning the system.

Storage

Choose clean sites for storage, not excessively humid and with temperatures between -10 and +60°C. If the products are to be stored for long periods of time, it is best not to remove them from their protective packaging. Keep the valves in the package during storage.

If the valves are not packaged, must be protected the ends to avoid liquid or other to penetrate during storage and thus damage the disc or the seals.

If the valves are to be stored for long periods of time, then they should be inspected periodically: check in particular the possible presence of rust, oxidation, paint nicks or even partial unscrewing of the closures. It is also recommended to perform a complete dry cycle of opening and closing of the valve.

The seals are subject to aging and lose of their characteristics: for this reason, after storage periods of more than two years, it is recommended to check the functionality and the seals before mounting the valve in the line.

Protect the seals from sun light (UV rays cause seal aging).

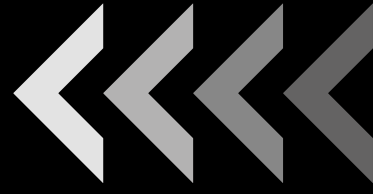

TROUBLESHOOTING

Potential Effects Of Failure	Potential Failure Mode	Solution
Valve leakage	Incomplete closing of the disc	Check the maneuvering system / Contact DENZ
	Liner worn	Replace worn parts as per instruction manual
	Chemical incompatibility with valve construction materials (gasket and / or lens)	Contact DENZ
	Disc worn	Check the chemical compatibility between the media and the construction materials / Contact DENZ
Leakage from Shaft	Damage on the stem seat or disc liner	Replace worn parts as per instruction manual
		Check the chemical compatibility between the media and the construction materials / Contact DENZ
Valve blocked	Damage on body	Contact DENZ
	Driving system fault	
	Disc / stem gripping	
	Stem break	
	Actuator- valve connection's break	
Increased maneuvering time / shooting motion	Disc / stem gripping	Check the chemical incompatibility with valve construction materials.
	Liner hardening	
	Partial actuator gripping	
Inadequate rotation angle	Actuator cannot perform the maneuver	Check actuator dimensioning and verify that actuator fluid pressure is equal to or greater than nominal pressure on plate
	Insufficient air supply to produce the required torque	
	Mechanical stop (if present) not properly adjusted	Adjust the stroke limiters
	Stem gripping	Contact DENZ
	Possible presence of blocked foreign body	Remove the valve and check its operation on the bench
	Incorrect fixing between actuator outlet hole and valve stem	Check for proper connecting kit between valve and actuator